

6" - 120W Professional Woofer

LP 165.32/ 426 WG 8 Ω

Code Z003990

GENERAL CHARACTERISTICS

Nominal Overall Diameter	165	mm
Nominal Voice Coil Diameter	32	mm
Magnet Weight	426	g
Flux Density.....	1.10	T
Weight.....	1.35	Kg

THIELE-SMALL PARAMETERS

Voice Coil DC Resistance	R_E	6.12	Ω
Resonance Frequency	f_s	72.8	Hz
Mechanical Q Factor.....	Q_{MS}	9.30	
Electrical Q Factor.....	Q_{ES}	0.53	
Total Q Factor	Q_{TS}	0.50	
Mechanical Moving Mass	M_{MS}	9.2	g
Mechanical Compliance	C_{MS}	520	μm/N
Force Factor	$B \times l$	6.96	Wb/m
Equivalent Acoustic Volume.....	V_{AS}	11.0	lt.
Maximum Linear Displacement	X_{MAX}	+/-2.5	mm
Reference Efficiency	η_0	0.77	%
Diaphragm Area	S_D	123.0	cm ²
Losses Electrical Resistance.....	R_{ES}	107.0	Ω
Voice Coil Inductance @ 1kHz	L_E	0.57	mH

CONSTRUCTIVE CHARACTERISTICS

Magnet.....	Ferrite
Voice Coil Winding.....	Copper
Voice Coil Former.....	Epotex
Cone	Paper
Surround.....	Rubber
Dust Dome	Treated Cloth
Basket	Pressed Sheet Steel

ELECTRICAL CHARACTERISTICS

Nominal Impedance.....	8	Ω
Musical Power	120	W
Rated Power*	60	W
Sensitivity @ 1 W, 1 m	92.0	dB

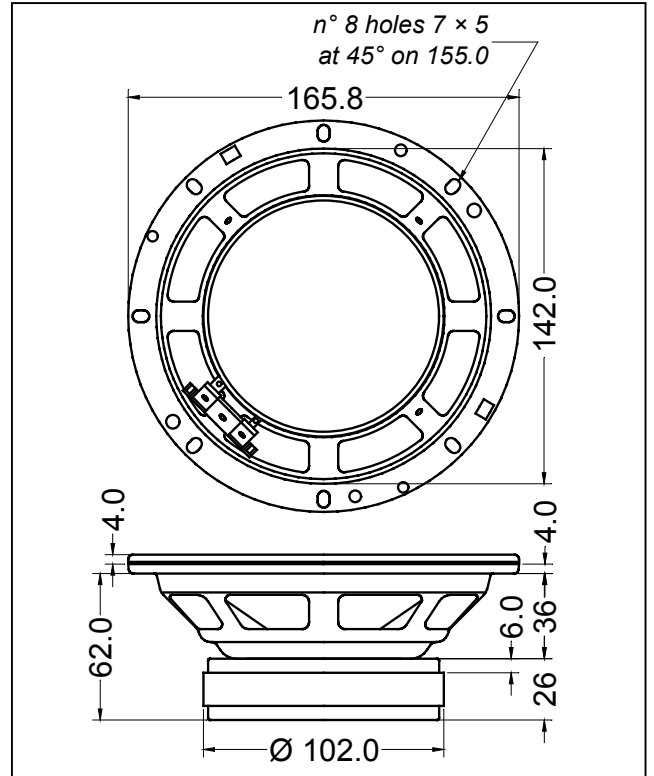

*rated power measured with 2 hours test with pink noise signal, 6 dB crest factor, loudspeaker mounted on enclosure

Frequency Response on IEC Baffle (DIN 45575) @ 1 W, 1 m - Impedance

