

18LW1250

Extended Low Frequency Ferrite Transducer

Key Features

- 98 dB SPL 1W / 1m average sensitivity
- 100 mm (4 in) Interleaved Sandwich Voice coil (ISV)
- 1000 W continuous pink noise power handling
- Weather protected cone and plates for outdoor usage
- Double Silicon Spider (DSS) for improved excursion control and linearity
- Improved heat dissipation via unique basket design and eight backplate vents



General Description

The 18LW1250 extended low frequency woofer represents the latest development in 18" (460 mm) high performance transducers. It has been designed for use as a low bass or sub-woofer component, in either a reflex, bandpass or horn loaded configuration, in high power loudspeaker systems.

The 18LW1250 design has evolved from extensive research carried out at our own R&D and Engineering facilities. It provides clean, undistorted low frequency reproduction at very high levels and is able to withstand high power without damage.

Its design features include a large displacement suspension system which in conjunction with a high quality cone and the Eighteen Sound Double Silicon Spider (DSS), assure a very linear piston action and provide full control across the entire working range.

This is further improved by a state-of-the-art voice coil, based on our Interleaved Sandwich Voice coil (ISV) technology. This provides high levels of thermal stability and durability. The ISV technology is based on a high strength fiberglass former with half the coil wound on the outside and half on the inside, bonded together using unique high temperature resin adhesives. The result is a balanced linear motor exerting a very high force factor.

Excellent heat dissipation is derived from a basket design which incorporates air channels between the basket and the magnetic top plate. In addition, 8 air vents in the back plate, aligned with the voice coil, force the air into the lower part of the gap.

Maximum flux density in the gap is assured by the special top and back plate design, resulting in a high BL factor.

Due to the increasing use of audio systems at outdoor events, the ability to perform in adverse weather conditions or in areas of high humidity is a key feature of the 18LW1250. This has been achieved using exclusive cone treatment and magnetic plate processes which increase resistance to corrosion and render the cone water repellent.

0221883150 8 Ohm

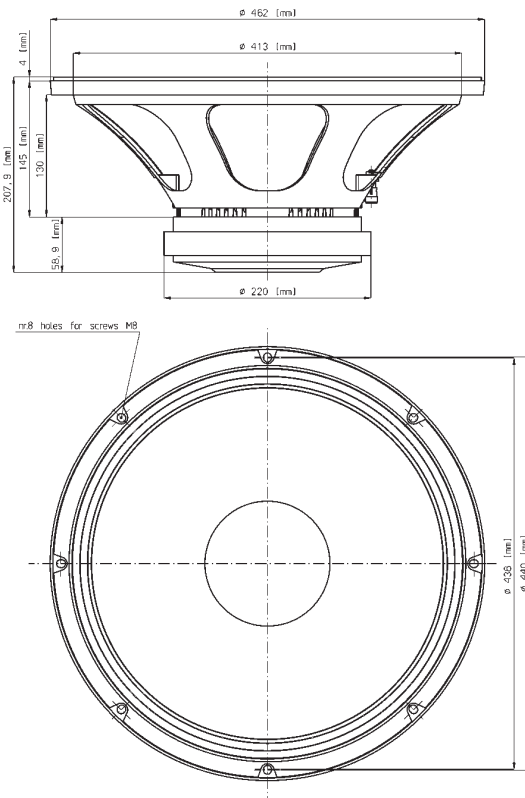

FERRITE LF-MB-MF TRANSDUCERS

18LW1250

Extended Low Frequency Ferrite Transducer

GENERAL SPECIFICATIONS

NOMINAL DIAMETER	460 mm (18 in)
RATED IMPEDANCE	8 Ohm
CONTINUOUS PINK NOISE (1)	1000 W
CONTINUOUS POWER (2)	700 W
PROGRAM POWER (3)	1400 W
PEAK POWER (4)	7000 W
SENSITIVITY (5)	98 dB
FREQUENCY RANGE (6)	35 - 3500 Hz
POWER COMPRESSION @-10DB (7)	(70 W) 0,7 dB
POWER COMPRESSION @-3DB	(350 W) 1,6 dB
POWER COMPRESSION @FULL POWER	(700 W) 2,6 dB
MAX RECOMM. FREQUENCY	500 Hz
RECOMM. ENCLOSURE VOLUME	120 ÷ 350 lt. (4,24 ÷ 12,36 cuft)
MINIMUM IMPEDANCE	6,4 Ohm at 25°C
MAX PEAK TO PEAK EXCURSION	36 mm (1,42 in)
VOICE COIL DIAMETER	100 mm (4 in)
VOICE COIL WINDING MATERIAL	copper
POLARITY	positive voltage on red terminal gives forward cone motion

THIELE SMALL PARAMETERS (8)

Fs	35 Hz
Re	5 Ohm
Sd	0,1134 sq.mt. (175,7 sq.in.)
Qms	8
Qes	0,28
Qts	0,27
Vas	268 lt. (9,47 cuft)
Mms	142 gr. (0,31 lb)
BL	23,6 Tm
Linear Mathematical Xmax (9)	± 9 mm (±0,35 in)
Le (1kHz)	2,73 mH
Ref. Efficiency 1W@1m (half space)	98 dB

MOUNTING INFORMATION

Overall diameter	462 mm (18,18 in)
N. of mounting holes	8
Mounting holes diameter	8,5 mm (0,33 in)
Bolt circle diameter	438-440 mm (17,24-17,32 in)
Front mount baffle cutout ø	416 mm (16,38 in)
Rear mount baffle cutout ø	412 mm (16,22 in)
Total depth	207,9 mm (8,18 in)
Flange and gasket thickness	19 mm (0,75 in)
Net weight	13 kg (28,7 lb)
Shipping weight	14,7 kg (32,45 lb)
CardBoard Packaging dimensions	482 x 482 x 257 mm (18,98 x 18,98 x 10,12 in)

FREQUENCY RESPONSE CURVE OF 18LW1250 MADE ON 180 LIT. ENCLOSURE TUNED 35HZ IN FREE FIELD (4PI) ENVIRONMENT. ENCLOSURE CLOSES THE REAR OF THE DRIVER. THE THIN LINE REPRESENTS 45 DEG. OFF AXIS FREQUENCY RESPONSE

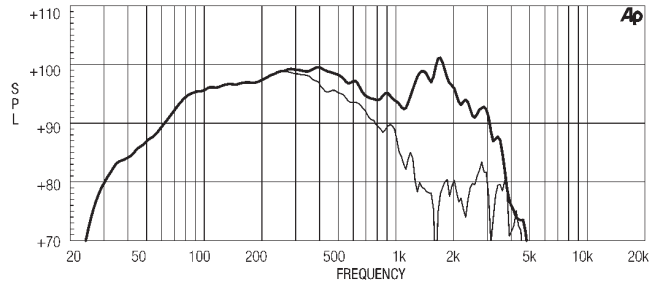

FREE AIR IMPEDANCE MAGNITUDE CURVE

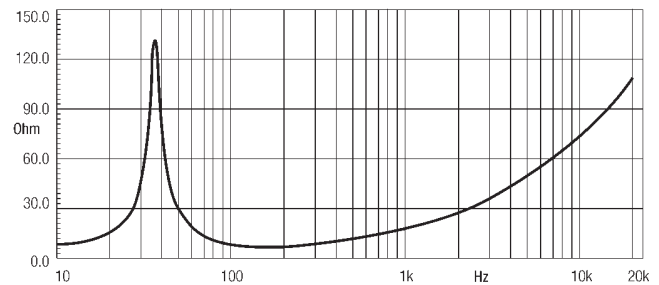

NOTES

- (1) AES standard
- (2) Continuous power rating is measured in 180 lit enclosure tuned 35Hz using a 40 - 400Hz band limited pink noise test signal applied continuously for 2 hours.
- (3) Program power rating is measured as for 2 above but 50% duty cycle.
- (4) The peak power rating is based on a 10dB crest factor above the continuous power rating and represents the maximum permitted instantaneous peak power level over a maximum period of 10ms which will be withstood by the loudspeaker without damage.
- (5) Sensitivity represents the averaged value of acoustic output as measured on the forward central axis of cone, at distance 1m from the baffle panel, when connected to 2,83V sine wave test signal swept between 100Hz and 500Hz with the test specimen mounted in the same enclosure as given for 2 above.
- (6) Frequency range is given as the band of frequencies delineated by the lower and upper limits where the output level drops by 10 dB below the rated sensitivity in half space environment.
- (7) Power compression represents the loss of sensitivity for the specified power, measured from 50-500 Hz, after a 5 min pink noise preconditioning test at the specified power.
- (8) Thiele - Small parameters are measured after the test specimen has been conditioned by 1000 W AES power and represent the expected long term parameters after a short period of use.
- (9) Linear Mat. Xmax is calculated as; $(Hvc-Hg)/2 + Hg/4$ where Hvc is the coil depth and Hg is the gap depth.

Eighteen Sound engages in research and product improvement. New materials and design refinements can be introduced into existing products without notice.

