

15W930

Extended LF Ferrite Transducer

KeyFeatures

- 98 dB SPL 1W / 1m average sensitivity
- 75 mm (3 in) edgewound copper voice coil
- 800 W program power handling
- Aluminum demodulating ring (SDR)
- Long excursion, linear travel suspension design
- Humidity resistant cone and treated plates for outdoor usage
- Ideal for high loading compact subwoofer applications and two way systems

Description

The 15W930 low frequency transducer meets the specific market demand for a ceramic version of our industry standard 15ND930 extended low frequency transducer with 75 mm Ø copper edge wound voice coil. Thanks to its versatility, the 15W930 can be used in 2-way compact reflex enclosures with a 1.4" compression driver, in multiway systems and in high loading sub woofers as small as 70 lt (compact reflex, bandpass and horn loaded configurations). The deep profile curvilinear cone, made with high strength wood pulp, has been designed to achieve the best possible linearity within its frequency range. The cone surround, made from a linen material, is highly resistant to aging and fatigue. The in-house developed cone treatment is humidity repellent and significantly dampens bell mode resonances. The 75mm (3in) copper edge-wound voice coil assembly is wound on a strong fibreglas former to improve force transmission and power handling. The already low distortion and high sound quality are further improved by the aluminum demodulating ring (SDR) used to reproduce instantaneous peak on mid frequencies, reducing intermodulation distortion. The magnetic structure has been optimized using our FEA CAD software that has maximized the flux density in the voice coil gap. Excellent heat dissipation has also been achieved by incorporating air channels between the basket and the magnetic top plate. Due to the increase in use of audio systems at outdoor events, the ability of the 15W930 to perform in adverse weather conditions or in areas of high humidity is a great advantage. This has been achieved using exclusive treatments which enable the cone and the magnetic plate to resist corrosion and render the cone water repellent at the same time.

Models

Model	Code	Information
0221589310	0221589310	8 Ohm

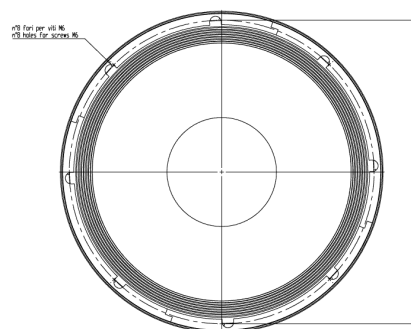
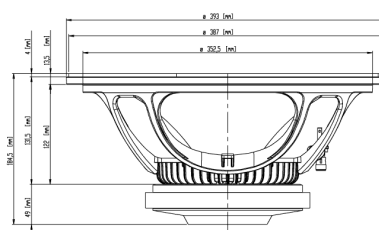

General Specifications

Nominal Diameter	380 mm (15 in)
Rated Impedance	8 Ohm
AES Power	500 W
Program Power	800 W
Peak Power	1600 W
Sensitivity	98 dB
Frequency Range	50 ÷ 3600 Hz
Power Compression @-10dB	0,6 dB
Power Compression @-3dB	1,9 dB
Power Compression @Full Power	2,8 dB
Max Recomm. Frequency	1700 Hz
Recomm. Enclosure Volume	60 ÷ 140 lt. (2,12 ÷ 4,95 cuft)
Minimum Impedance	7,2 ohm at 25°C
Max Peak To Peak Excursion	33 mm (1,30 in)
Voice Coil Diameter	75 mm (3 in)
Voice Coil Winding Material	Edgewound Copper
Suspension	M-roll, Polycotton
Cone	Curvilinear, humidity repellent

Thiele Small Parameters

Fs	33 Hz
Re	5,5 Ohm
Sd	0,086 sq.mt. (132,53 sq.in.)
Qms	8,78
Qes	0,23
Qts	0,22
Vas	240 lt. (8,46 cuft)
Mms	97 gr. (0,21 lb)
BL	22,1 Tm
Linear Mathematical Xmax	± 7,5 mm (± 0,30 in)
Le (1kHz)	1,47 mH
Ref. Efficiency 1W@1m (half space)	97,9 dB

Mounting information

Overall diameter	393 mm (15,47 in)
N. of mounting holes and bolt	8
Mounting holes diameter	7,15 mm (0,28 in)
Bolt circle diameter	371 mm (14,6 in)
Front mount baffle cutout ø	360 mm (14,17 in)
Rear mount baffle cutout ø	354 mm (13,94 in)
Total depth	185 mm (7,28 in)
Flange and gasket thickness	14 mm (0,55 in)
Net weight	7,6 kg (16,7 lb)
Shipping weight	8,5 kg (18,7 lb)
CardBoard Packaging dimensions	405 x 405 x 252 mm (15,94 x 15,94 x 9,92 in)

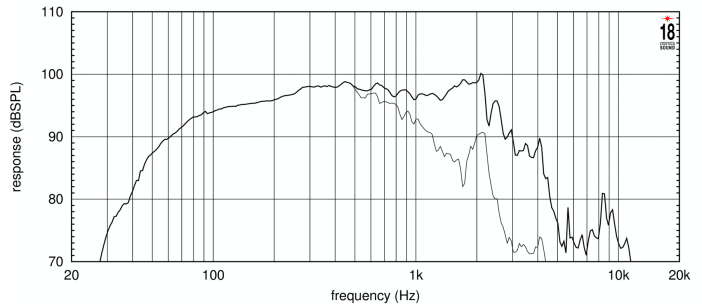

FREQUENCY RESPONSE CURVE MADE ON 125 LIT. ENCLOSURE TUNED 50HZ IN FREE FIELD (4PI) ENVIRONMENT. ENCLOSURE CLOSES THE REAR OF THE DRIVER. THE THIN LINE REPRESENTS 45 DEG. OFF AXIS FREQUENCY RESPONSE

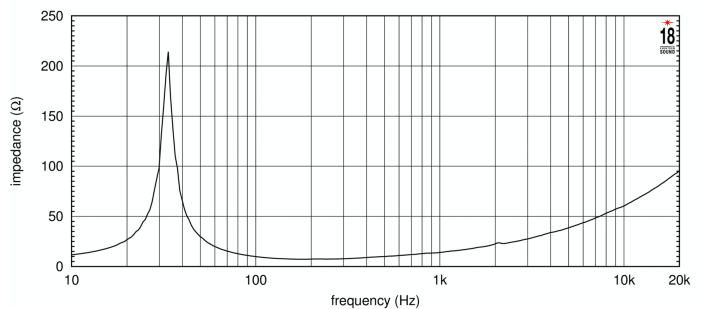

FREE AIR IMPEDANCE MAGNITUDE CURVE

Notes

- 1) AES power is determined according to AES2-1984 (r2003) standard
- 2) Program power rating is measured in 125 lit enclosure tuned 50Hz using a 40 - 400Hz band limited pink noise test signal with 50% duty cycle, applied for 2 hours.
- 3) The peak power rating represents the maximum permitted instantaneous peak power level over a maximum period of 10ms which will be withstood by the loudspeaker without damage.
- 4) Sensitivity represents the averaged value of acoustic output as measured on the forward central axis of cone, at distance 1m from the baffle panel, when connected to 2,83V sine wave test signal swept between 100Hz and 500Hz with the test specimen mounted in the same enclosure as given for (1) above.
- 5) Frequency range is given as the band of frequencies delineated by the lower and upper limits where the output level drops by 10 dB below the rated sensitivity in half space environment.
- 6) Power compression represents the loss of sensitivity for the specified power, measured from 50-500 Hz, after a 5 min pink noise preconditioning test at the specified power.
- 7) Linear Math. Xmax is calculated as $(Hvc-Hg)/2 + Hg/4$ where Hvc is the coil depth and Hg is the gap depth.