

10MB600

High Output Midbass Ferrite Transducer

Key Features

- 98 dB SPL 1W / 1m average sensitivity
- 75 mm (3 in) Interleaved Sandwich Voice coil (ISV)
- 450 W continuous pink noise power handling
- Weather protected cone and plates for outdoor usage
- Excellent transient response
- Ideal for compact two way and multiway systems
- Improved heat dissipation via unique basket design



General Description

The 10MB600 mid-bass transducer represents a development of the 10M600 midrange, combining excellent linearity with high efficiency and high power handling capabilities. The 10MB600 is primarily intended for use as a midbass driver in extremely compact 2-way reflex enclosures between 10 and 40 lt.

Its curvilinear paper cone is formed using a special high strength wood pulp, designed to achieve the best possible rigidity and stiffness. An exclusive treatment is also applied to the cone to increase its water repellent properties.

The 75 mm state-of-the-art voice coil is similar to those fitted to our top-of-the-range 18" and 15" models but it is wound with aluminum wire. The coil also employs our Interleaved Sandwich Voice coil (ISV) technology. A high strength fiberglass former carries windings on both the outer and inner surfaces to achieve a mass balanced coil, resulting in an extremely linear motor assembly with a reduced tendency for eccentric behavior when driven hard.

The voice coil cooling is achieved using airways between the chassis back plate and the face plate of the magnet which allow heated air from the voice coil and gap to be channeled away and dissipated by the chassis basket. This technology is a result of 3D CAD resource application by our engineers.

The top and back plates of the magnet assembly have been designed to optimise flux density and BL factor in the air gap also using our in-house FEA CAD facility.

In addition, a special treatment is applied to the top and back plates making the transducer far more resistant to the corrosive effects of salts and oxidization. Hence, the equipment is able to perform outdoors in inclement weather conditions.

0221065210 16 Ohm
0221085210 8 Ohm

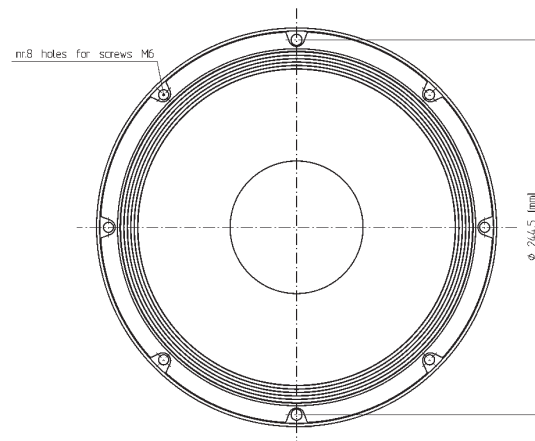
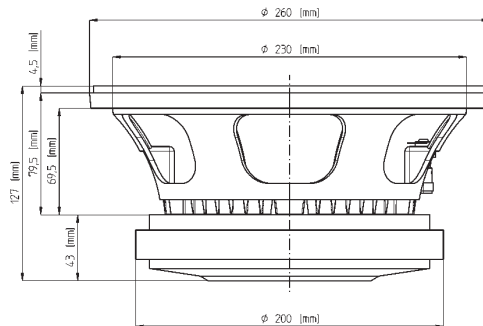

FERRITE LF-MB-MF TRANSDUCERS

10MB600

High Output Midbass Ferrite Transducer

GENERAL SPECIFICATIONS

NOMINAL DIAMETER	260 mm (10 in)
RATED IMPEDANCE	8 Ohm
CONTINUOUS PINK NOISE (1)	450 W
CONTINUOUS POWER (2)	350 W
PROGRAM POWER (3)	700 W
PEAK POWER (4)	1500 W
SENSITIVITY (5)	98 dB
FREQUENCY RANGE (6)	55 ÷ 4500 Hz
POWER COMPRESSION @-10DB (7)	(35 W) 0,4 dB
POWER COMPRESSION @-3DB	(175 W) 1,6 dB
POWER COMPRESSION @FULL POWER	(350 W) 2,2 dB
MAX RECOMM. FREQUENCY	2500 Hz
RECOMM. ENCLOSURE VOLUME	10 ÷ 40 lt. (0,9 ÷ 1,41 cuft)
MINIMUM IMPEDANCE	6,4 Ohm at 25°C
MAX PEAK TO PEAK EXCURSION	24 mm (0,94 in)
VOICE COIL DIAMETER	75 mm (2,95 in)
VOICE COIL WINDING MATERIAL	aluminum
POLARITY	positive voltage on red terminal gives forward cone motion

THIELE SMALL PARAMETERS (8)

Fs	58 Hz
Re	5,7 Ohm
Sd	0,035 sq.mt. (54,25 sq.in.)
Qms	5,5
Qes	0,23
Qts	0,22
Vas	33,4 lt. (1,18 cuft)
Mms	38 gr. (0,08 lb)
BL	18,6 Tm
Linear Mathematical Xmax (9)	± 6,5 mm (± 0,26 in)
Le (1kHz)	1,6 mH
Ref. Efficiency 1W@1m (half space)	96,5 dB

MOUNTING INFORMATION

Overall diameter	260 mm (10,24 in)
N. of mounting holes	8
Mounting holes diameter	7,15 mm (0,28 in)
Bolt circle diameter	244,5 mm (9,63 in)
Front mount baffle cutout ø	232 mm (9,13 in)
Rear mount baffle cutout ø	232 mm (9,13 in)
Total depth	127 mm (5 in)
Flange and gasket thickness	14,5 mm (0,57 in)
Net weight	7,35 kg (16,23 lb)
Shipping weight	7,9 kg (17,44 lb)
CardBoard Packaging dimensions	275 x 275 x 164 mm (10,83 x 10,83 x 6,46 in)

FREQUENCY RESPONSE CURVE OF 10MB600 MADE ON 30 LIT. ENCLOSURE TUNED 55HZ IN FREE FIELD (4PI) ENVIRONMENT. ENCLOSURE CLOSES THE REAR OF THE DRIVER. THE THIN LINE REPRESENTS 45 DEG. OFF AXIS FREQUENCY RESPONSE

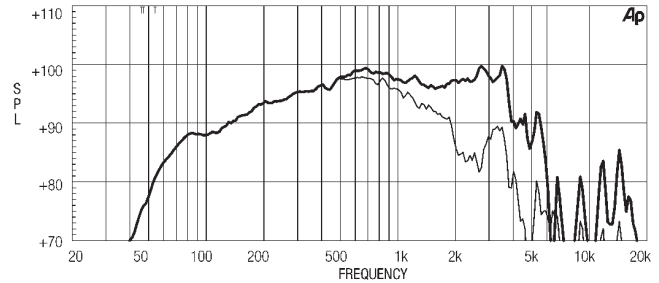

FREE AIR IMPEDANCE MAGNITUDE CURVE

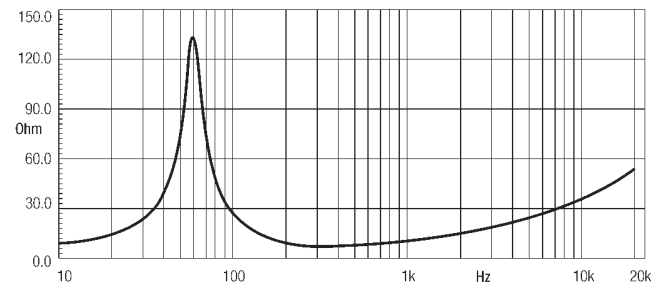

NOTES

- (1) AES standard
- (2) Continuous power rating is measured in 30 lit enclosure tuned 55Hz using a 70 - 2000Hz band limited pink noise test signal applied continuously for 2 hours.
- (3) Program power rating is measured as for 2 above but 50% duty cycle.
- (4) The peak power rating is based on a 6dB crest factor above the continuous power rating and represents the maximum permitted instantaneous peak power level over a maximum period of 10ms which will be withstood by the loudspeaker without damage.
- (5) Sensitivity represents the averaged value of acoustic output as measured on the forward central axis of cone, at distance 1m from the baffle panel, when connected to 2,83V sine wave test signal swept between 500Hz and 2500Hz with the test specimen mounted in the same enclosure as given for 2 above.
- (6) Frequency range is given as the band of frequencies delineated by the lower and upper limits where the output level drops by 10 dB below the rated sensitivity in half space environment.
- (7) Power compression represents the loss of sensitivity for the specified power, measured from 50-500 Hz, after a 5 min pink noise preconditioning test at the specified power.
- (8) Thiele - Small parameters are measured after the test specimen has been conditioned by 450 W AES power and represent the expected long term parameters after a short period of use.
- (9) Linear Mat. Xmax is calculated as; $(Hvc-Hg)/2 + Hg/4$ where Hvc is the coil depth and Hg is the gap depth.

Eighteen Sound engages in research and product improvement. New materials and design refinements can be introduced into existing products without notice.